

Brushless Motors and Controllers

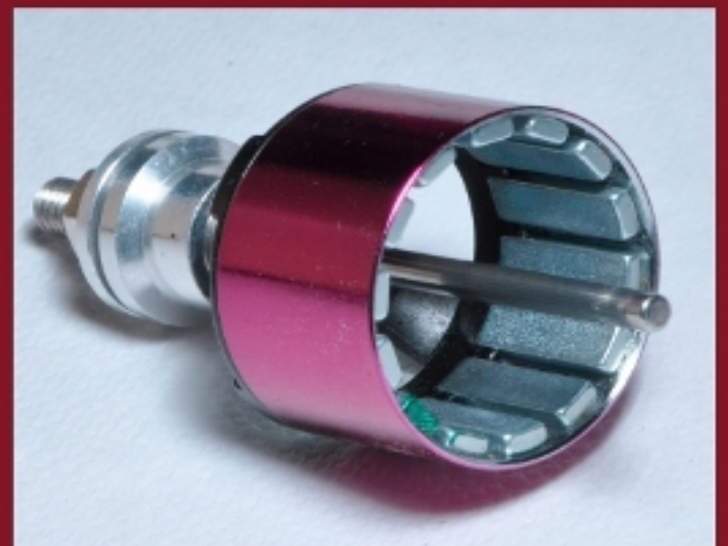

Brushless Motors and Controllers

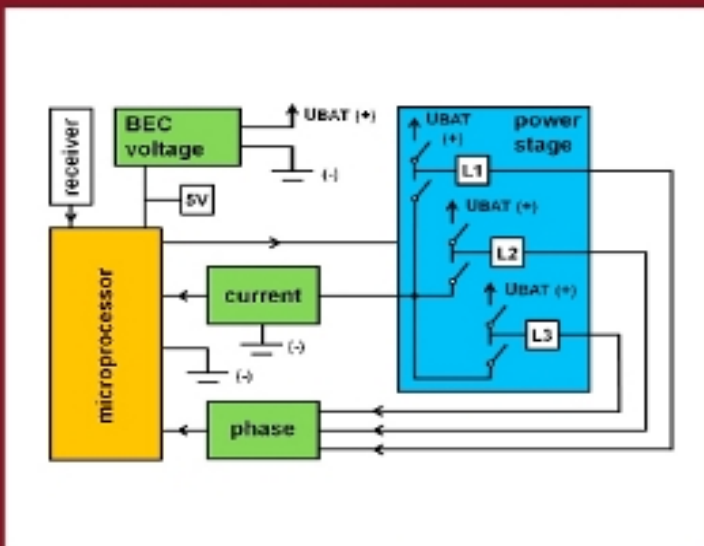
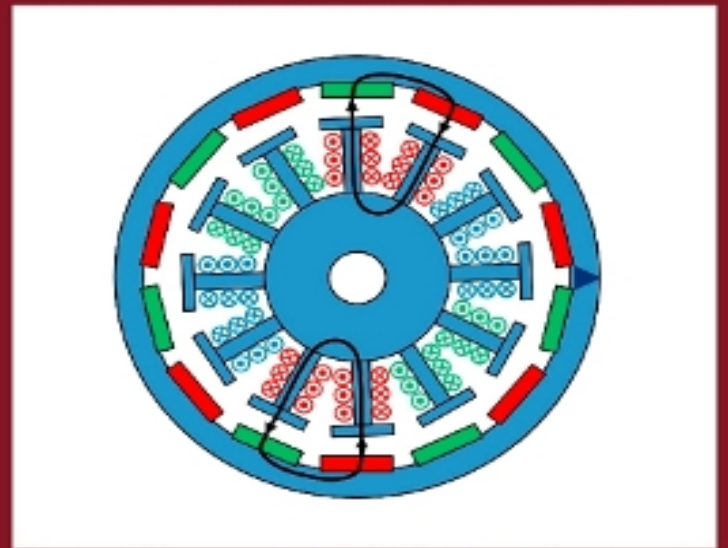
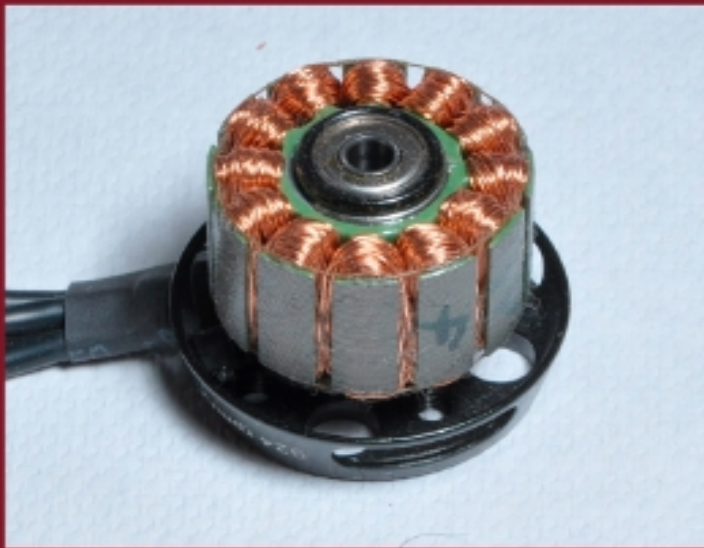
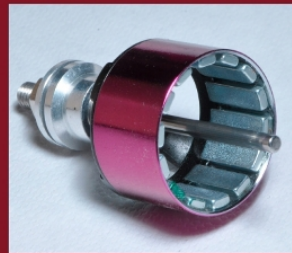
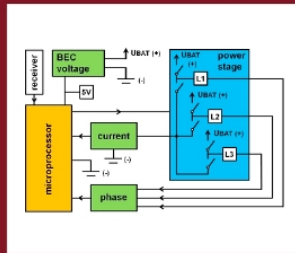
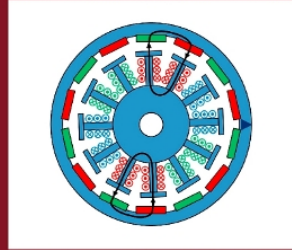

Roland Büchi

Brushless Motors and Controllers

Books on Demand

Preamble

Brushless DC motors and controllers have begun an unparalleled triumph in recent years in all technical fields and also in model construction. It is not just that they are now an alternative to the brushed or DC motors. No, they have in many fields almost completely driven these out of business.

But what are the apparently strong arguments that speak for this new technology? As a model constructor one simply buys a finished motor and controller unit for the airplane, car or boat model. And then one enjoys, together with the LiPo battery, a huge difference when comparing the available power and the flight or drive time with what was previously possible. The only thing you can see from the outside as the difference is that between the controller and the brushless motor there are now three wires instead of only two, as was the case with brushed motors.

This book is intended to show the interested reader how a brushless motor works, what its properties are, and what the reasons are that have led to its success. The basic principle is discussed first, before all the key terms such as kV and rpm/V, operating voltage, load and no-load current, torque, turns, electrical and mechanical power, losses, efficiency, etc. are explained.

A brushless motor can't work without a brushless controller. The batteries supply only a DC voltage, whereas a brushless motor requires a so-called three-phase AC voltage. Thus it is microprocessor technology together with powerful transistors which enables the operation.

To increase speed properly, the controller must have information on the rotor position, the so-called phase zero crossing. The measurement is done in most cases without sensors, directly via the motor windings. In many applications there are, however, Hall sensors which perform this measurement. They have some advantages in the startup phase, but the disadvantage of the higher price. Both types will be taken into account in the book. Since industrial drives are also often designed as brushless motors with one of these two measurement methods, the book is also of interest to technicians.

However, the theory here is to be executed only as far as it helps the reader to understand the principles. For better understanding, practical examples will always be presented. At the end of most chapters, each of the key findings is presented in short form. In this way, also the technical layman gains a basic understanding of this technology.

Of course, there are also practical examples of motor and controller combinations discussed in the book. Several cases of controllers and motors of different power are examined. The load cases of the different types of models - propellers on model aircraft, helicopters in Governor mode, ship propellers of model boats or the acceleration and braking of cars - play a big role. They all find their place here, and the specialties of these drive units are also considered here.

There are several ways in which the settings of brushless controllers can be carried out. Some work on an integrated programming mode, which communicates with the user via switches, LEDs and beeps. Often, parameters can be saved using the throttle stick of the remote control. More elaborate versions make use of so-called programming boxes, which are plugged directly to the controller for setting the

parameters. Another type of programming is done via USB port on the PC. With the included software it is possible to change a variety of parameters graphically on the screen.

Also important are practical tips for proper installation in the model and tips on wiring. Since in operation both the motor and the controller generate power loss and therefore heat, the discussion about the proper cooling of both units is very important. Notes for the purchasing decision and the right procedure for troubleshoot are also essential and complete the book. References are listed at the end

Contents

1. Introduction

- 1.1 Electro-mechanical energy converter
- 1.2 Differences between brushed and brushless motor
- 1.3 No brushless motor without brushless DC controller
- 1.4 Brushless DC motor or just brushless motor?

2. Working principle of the brushless motor

- 2.1 Active principle
- 2.2 Action of force on a current-carrying conductor in a magnetic field
- 2.3 Force action in practice on the example of an inrunner
- 2.4 More stator slots and magnetic poles on the examples of outrunners 6S8P and 12S14P
- 2.5 Star connection, delta connection
- 2.6 Findings in brief

3. Characteristics of the brushless motor

- 3.1 kV, rpm/V
- 3.2 Winding resistor
- 3.3 Motor characteristics
- 3.4 Turns
- 3.5 Motor power
- 3.6 Braking operation
- 3.7 Efficiency
- 3.8 Findings in brief

4. Brushless DC Controllers

- 4.1 Powerstage
- 4.2 Timing and phase measurement

- 4.3 Maximum current, current and temperature measurement
- 4.4 BEC voltage
- 4.5 Low voltage measurement
- 4.6 Operation modes, stick position = voltage or speed
- 4.7 Microcontroller and setting the parameters
- 4.8 Findings in brief

5. Practical examples

- 5.1 Practical tips for cabling
- 5.2 Graupner Compact drive
- 5.3 Modification of a monster truck to a brushless motor

6. Sources of error

- 6.1 Short to frame, short-circuited coil, short circuit
- 6.2 Bearing and shaft
- 6.3 Defective power stage of the controller

1. Introduction

Brushless DC motors – or BLDC motors in short – are an indispensable part of modern drive technology. Other names are also EC (electronic commutated) motor or synchronous motor. They have for many years been standard for actuating drives or also for electrical power generation. However, the use of miniature motors up to the kilowatt range was reserved for a long time for brushed (DC) motors. At the beginning of the technology of power electronics, DC was much easier to control. But as considered in more detail later, brushless motors need multi-phase, mostly three-phase AC. It was at that time very complex to produce that in the different frequencies and voltages required. So their use was only worthwhile for larger power classes.

But today's microprocessor technology combined with efficient transistors of the smallest size allowed since the beginning of the 21st Century that ever-smaller brushless motors have been competitive in price compared to DC motors. As will be shown, they are superior to DC motors in many ways, either because of the low wear or the high efficiency. Anyone who has ever replaced a DC drive with a brushless drive will therefore never look back on the other technology.

This is particularly true for model construction. In the last years of the 20th Century almost all small electric motors were brushed. Here, the change to brushless drives took place within a few years. The many benefits of this technology ensured that they became not only the standard drives for boat and car models, but even for flight models. This is particularly interesting because there they need to compete with combustion engines. For a long time these seemed to be undisputed in terms of power density.

1.1 Electro-mechanical energy converter

Electric motors are so-called electro-mechanical energy converters. They convert electrical energy or power into mechanical energy or power. Both electrical and mechanical power are important for the user. Electrical power is relevant for the calculation of how long it takes until the battery is empty. The mechanical power is what drives the model; that is, what one can see or feel. [Figure 1](#) shows the relations. As can be seen from this, energy conversion cannot be done in practice without loss. There are always losses in the motor.

It can be deduced that for each electrical motor the following equation is valid:

$$P_{EL} = P_{MECH} + P_L$$

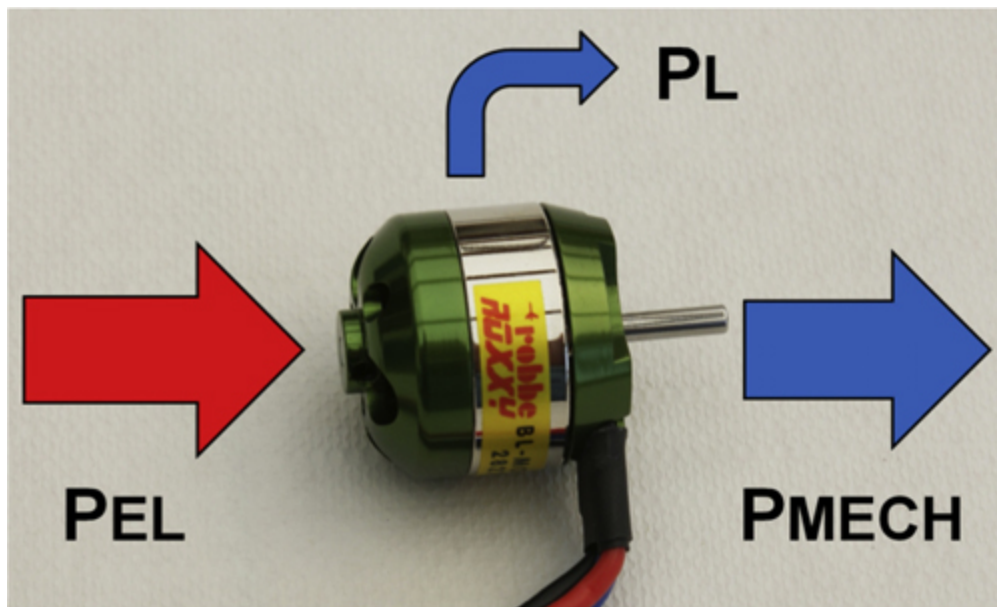

Figure 1: Power distribution

P_L is the total power loss. As will be shown later, it consists of the losses in the winding, the losses in the iron and the friction between the shaft and bearings.

The mechanical power in the motor operation is always smaller than the electrical power. The manufacturers are very interested in maintaining the ratio between the mechanical and electrical power as high as possible. This is the motor efficiency. It's not just about the optimum use of electrical power. If high efficiency is achieved, then this also means that the power loss during operation is small. Then the heat in the drive is low. This increases the life span. Due to the special technology of brushless motors, the efficiencies are in most cases in the operating range between 80% and 90%, and often even more. In comparison to that, brushed motors or DC motors achieve efficiencies which lie between 50% and 80%. Brushed motors with comparable power thus have much higher power dissipation. They will thus in operation under the same conditions get warmer or have to be built bigger and heavier to dissipate the heat.

Power classes

Later it will be shown that the stator surface, i.e. the non-rotating part, determines how big the maximum power loss of the motor may be. Thus, if the efficiency is high, with a given stator surface a large mechanical power can also be achieved. Of course most of the motors used in models lie in the power class of a few watts to several hundred watts. But there are also drives with up to 15 kW and more built and operated successfully. Together with the high-performance accumulators and controllers of today the largest model aircraft, boats and cars can also be operated. The brushless drive is the drive of the present and future. With the development of even stronger powered systems, the number of combustion engine powered models will decrease further.

1.2 Differences between brushed and brushless motor

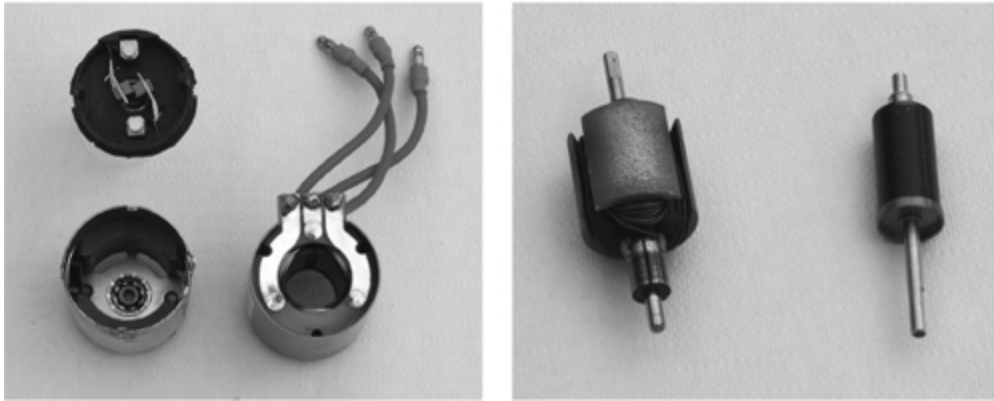

Figure 2: Stators and rotors of brushed and brushless motors

Figure 2 shows stators and rotors of brushed and brushless motors. On the left of the left-hand image is a stator and brushes of a brushed motor, while to the right is the stator of a brushless motor. The right image shows on the left a rotor of a brushed and on the right a rotor of a brushless motor. Both motor types are so-called inrunners. The fixed part, the stator, is located outside and the rotating part, the rotor, is inside.

Both motors are moving with the same principle of Lenz's law, as will be discussed in detail in Section 2.2. Under this principle, (permanent) magnets and current-carrying conductors always exert forces on each other. With a brushed motor, the permanent magnets are always mounted on the stator. The current-carrying conductors are always located on the turning part. However, the magnetic field caused by the permanent magnet and the current through the conductor only exerts a force in the direction of rotor rotation when they are in the correct orientation relative to one another. This means that the current will be reversed during the rotation. This is in technical language also called 'commutation'. The brushes are needed to establish a contact between the stator and the wires of the

turning rotor. In addition, they commutate the current. They are usually made of graphite. To minimize wear and enhance contact, they are often enriched with copper, silver or other metals. Brushed motors have the advantage that they can be driven with a DC voltage, as provided by a battery or an accumulator. The commutation with the brushes then ensures the correct flow direction. Therefore, these motors are also called direct current (DC) motors.

But it is precisely this connection between the rotor and the stator which is the weak point of these motors. On the one hand, the power transfer requires a certain pressure between brushes and rotor, which increases the friction and reduces the efficiency, while on the other hand the lower efficiency then means that the motor generates more power loss in operation. The resulting heat just wears off again the main cause of low efficiency, namely these same brushes. Inductances in the motor also ensure that the abrupt change of current flow during commutation causes large overvoltage peaks. The resulting so-called brush fire disturbs the receiver of the remote control. The brushed motor must therefore be de-jammed.

With brushless motors, the permanent magnets are always attached to the rotating part, the rotor. The current-carrying conductors are however always located on the stator. This situation is therefore exactly the reverse to the one with brushed motors. Placed in this way, the current does not need to be transferred to the rotor. The brushes are therefore eliminated.

One might almost ask at this point why the technology has made such a long detour via the brushed motor. Ultimately, it's much easier if the wearing parts of the brushes are not needed at all. The answer lies in the commutation. A brushless motor can't operate directly with a DC voltage from a battery. The commutation must be resolved in a different way. What is done with brushed motors mechanically is done with brushless motors through the

electronics of the brushless DC controller. Commutate current also means changing current direction, or indeed using alternating current, AC. The brushless controller turns the DC battery power to AC. Only this ensures that the motor is turning.

It is a fact that it can be seen very often in modern technology: a problem which was earlier solved purely mechanically is now replaced by a combination of electronics and much simpler mechanics. Other examples are the wheel hub motor in bicycles, instead of a chain drive and a gear, or 'fly by wire' of a large aircraft, instead of mechanical transmission rods. An example in model construction is the replacement of the complicated helicopter mechanism by four speed-controlled propellers of a quadcopter. The brushless motor is thus in good and modern company.

1.3 No brushless motor without brushless DC controller

The above title is immediately clear. A brushless motor can't yet rotate on its own because the highly important commutation is absent. This is immediately clear to anyone who holds such a motor with three wires in his hand the first time. How can he connect these with only the two wires of the battery? Therefore a regulator is mandatory. These two things are inextricably linked.

In the early days of model construction with brushed motors and remote controls with few channels, it was still possible (but not advisable) to connect the motor directly to the battery, without the possibility of intervention. For the above reasons, today's brushless drives must always consist of motor and controller. [Figure 3](#) shows such a standard combination; [Figure 4](#) is a schematic representation of this.

As shown in Chapter 4, the brushless DC controllers almost always have a so-called BEC (Battery Eliminator Circuit) connector. This provides the receiver with energy and can be seen in the figures too.

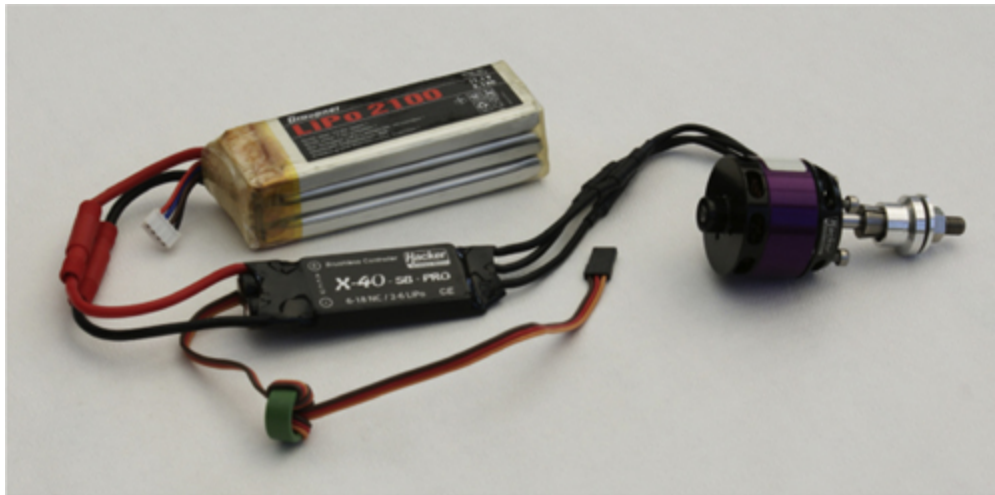

Figure 3: Standard drive combination

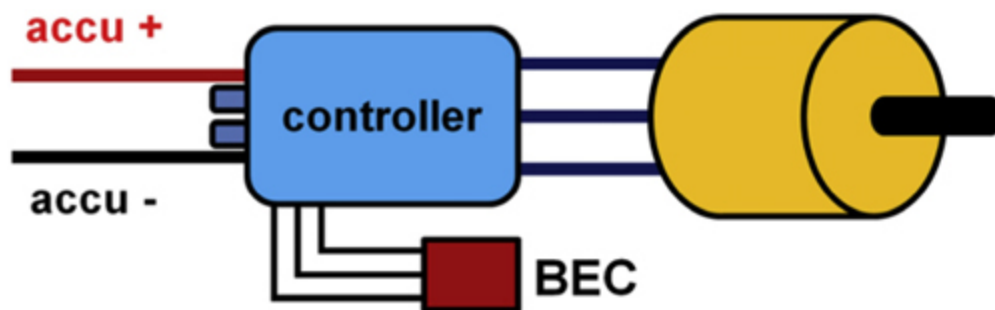

Figure 4: Schematic illustration of the drive in Figure 3

1.4 Brushless DC motor or just brushless motor?

The correct naming is almost a question of philosophy. The brushless motor is mentioned in the literature, sometimes abbreviated as BL motor and sometimes as BLDC motor. Depending on whether the motor is only meant for use by itself or in combination with the control, both terms are correct. The fact is, the motor itself has nothing to do with DC. DC means Direct Current. The simple designation