

# **Geometry**

## **A Self-Teaching Guide**

**Steve Slavin**  
**Ginny Crisonino**



WILEY

**John Wiley & Sons, Inc.**



# **Geometry**

## **A Self-Teaching Guide**



# **Geometry**

## **A Self-Teaching Guide**

**Steve Slavin**  
**Ginny Crisonino**



**WILEY**

**John Wiley & Sons, Inc.**

This book is printed on acid-free paper. ☺

Copyright © 2005 by Steve Slavin and Ginny Crisonino. All rights reserved.

Published by John Wiley & Sons, Inc., Hoboken, New Jersey  
Published simultaneously in Canada

No part of this publication may be reproduced, stored in a retrieval system, or transmitted in any form or by any means, electronic, mechanical, photocopying, recording, scanning, or otherwise, except as permitted under Section 107 or 108 of the 1976 United States Copyright Act, without either the prior written permission of the Publisher, or authorization through payment of the appropriate per-copy fee to the Copyright Clearance Center, 222 Rosewood Drive, Danvers, MA 01923, (978) 750-8400, fax (978) 646-8600, or on the web at [www.copyright.com](http://www.copyright.com). Requests to the Publisher for permission should be addressed to the Permissions Department, John Wiley & Sons, Inc., 111 River Street, Hoboken, NJ 07030, (201) 748-6011, fax (201) 748-6008.

**Limit of Liability/Disclaimer of Warranty:** While the publisher and the author have used their best efforts in preparing this book, they make no representations or warranties with respect to the accuracy or completeness of the contents of this book and specifically disclaim any implied warranties of merchantability or fitness for a particular purpose. No warranty may be created or extended by sales representatives or written sales materials. The advice and strategies contained herein may not be suitable for your situation. You should consult with a professional where appropriate. Neither the publisher nor the author shall be liable for any loss of profit or any other commercial damages, including but not limited to special, incidental, consequential, or other damages.

For general information about our other products and services, please contact our Customer Care Department within the United States at (800) 762-2974, outside the United States at (317) 572-3993 or fax (317) 572-4002.

Wiley also publishes its books in a variety of electronic formats. Some content that appears in print may not be available in electronic books. For more information about Wiley products, visit our web site at [www.wiley.com](http://www.wiley.com).

ISBN 0-471-38634-0

Printed in the United States of America

10 9 8 7 6 5 4 3 2 1

# Contents

	<i>Introduction</i>	1
<b>1</b>	The Basics	3
<b>2</b>	Triangles	24
<b>3</b>	Circles	68
<b>4</b>	Perimeter and Area of Two-dimensional Polygons	120
<b>5</b>	Volume and Surface Area of Three-dimensional Polygons	162
<b>6</b>	Conic Sections	193
	<i>Index</i>	271





# Introduction

The best thing about this book is that you don't need to know a whole lot of math to be able to read it. If you can add, subtract, multiply, and divide, then you're all set. Before you know it, you'll know all about every geometric shape from circles and squares to cubes, spheroids, and cones.

Like readers of all the other self-teaching guides in this series, you'll work your way through this book problem by problem. We'll be right there with you every step of the way. And you'll find a full solution to each problem in the book. So you can check your work, go back over things that you need to review, and work at your own pace.

The chances are, much of what you'll see in the first three chapters will be quite familiar. At the beginning of each chapter is a pretest, so if you score well, you may skip part or all of the chapter. Even so, for the sake of review, you may want to work your way through these chapters.

You'll notice that there are several self-tests within each chapter, so you can constantly monitor your progress. It will be up to you to be completely honest with yourself. You'll need to keep asking: Self, do I really understand everything in this section? If the answer is no, you'll need to reread that section and redo each problem. Generally, you should do this if you get more than one wrong answer on a self-test.

Some people love geometry, while others hate it. We hope you'll have as much fun reading our book as we did writing it. But then again, we already knew this stuff before we started. By the time you've finished reading this book, maybe you'll be ready to write your own book.

Ginny Crisonino has taught mathematics at Union County College in Cranford, New Jersey, since 1983. Together with her fabulous coauthor, Steve Slavin, she has written *Precalculus: A Self-Teaching Guide* (published by Wiley) and *Basic Mathematics* ( $\pi r^2$  Publishing Company), a college text now in its second edition. Steve Slavin taught economics for 30 years and has authored or coauthored 14 books in mathematics and economics, including *Economics* (McGraw-Hill), a college text now in its seventh edition, and *All the Math You'll Ever Need* (Wiley), now in its second edition and a Literary Guild selection.



# 1 The Basics

Chapter 1 reviews some of the basic concepts of geometry. When you've completed this chapter, you should be able to work with the following concepts:

- points and lines
- angles
- polygons

At the beginning of each chapter we'll give you a pretest. If you get a perfect score on a pretest without peeking at the answers that follow, it's probably all right to skip that chapter. Before we begin chapter 1, try the following pretest to get an idea of how much review you need, if any. If you get a perfect score on the pretest, you may skip chapter 1 and go directly to chapter 2.

## PRETEST

1. Find the distance between the following sets of points.
  - a.  $(1,9)$  and  $(3,7)$
  - b.  $(-2,6)$  and  $(6,-2)$
2. Find the midpoint of both line segments in the previous problem.
3. List all the line segments for the following line.

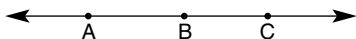

## 4 GEOMETRY

---

4. List all the rays of the following illustration.

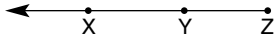

5. Use a protractor to measure the following angles.

a.

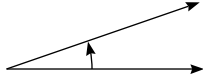

b.

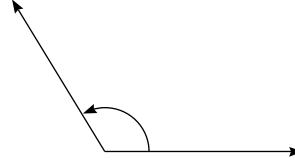

c.

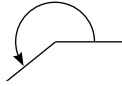

d.

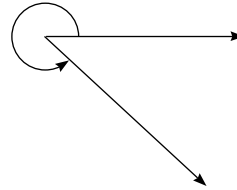

6. Without using a protractor, state the values of the angles in the following figure.

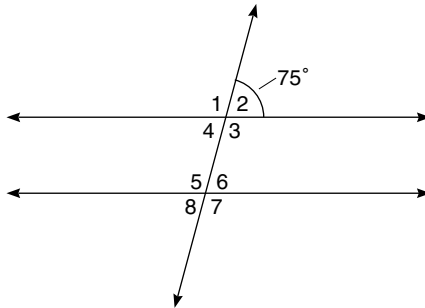

7. Find the value of  $x$  in the following figure.

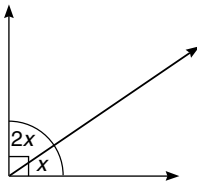

8. State whether the following angles are acute, obtuse, right, or straight.

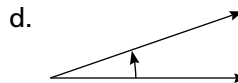
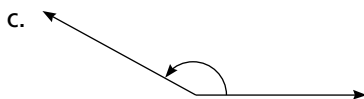
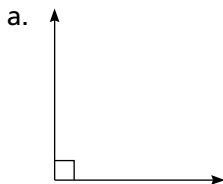

9. What's the sum of the measure of the angles of a hexagon?

10. What kind of quadrilateral has four right angles but not all sides are equal?

## ANSWERS

1. a.  $d = \sqrt{(3-1)^2 + (7-9)^2} = \sqrt{4+4} = \sqrt{8} = 2\sqrt{2} \approx 2.83$

b.  $d = \sqrt{(6+2)^2 + (-2-6)^2} = \sqrt{64+64} = \sqrt{128} = 8\sqrt{2} \approx 11.31$

2. a. *Midpoint:*

$$\left(\frac{1+3}{2}, \frac{9+7}{2}\right) = (2, 8)$$

b. *Midpoint:*

$$\left(\frac{-2+6}{2}, \frac{6+2}{2}\right) = (2, 2)$$

3.  $\overline{AB}$   $\overline{AC}$   $\overline{BC}$       4.  $\overleftrightarrow{ZX}$   $\overleftrightarrow{ZY}$

5. a.  $20^\circ$       b.  $120^\circ$       c.  $220^\circ$       d.  $320^\circ$

6.  $\angle 1 = \angle 3 = \angle 5 = \angle 7 = 105^\circ$        $\angle 2 = \angle 4 = \angle 6 = \angle 8 = 75^\circ$

7.  $x + 2x = 90^\circ$

$$3x = 90^\circ$$

$$x = 30^\circ$$

8. a. right      b. straight      c. obtuse      d. acute

9.  $(6-2)180^\circ = 4(180^\circ) = 720^\circ$       10. rectangle

## Points and Lines

Let's start with something you probably know. Fill in the rest of this sentence:

The shortest distance between two points is \_\_\_\_\_.

Did you know the answer? *The shortest distance between two points is a straight line.*

*Example 1:*

Find the distance between the points (0,4) and (4,2).

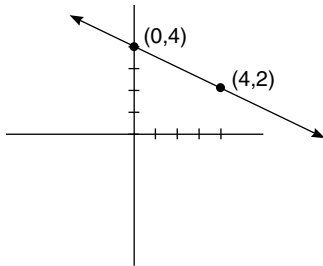

*Solution:*

The distance formula is used to find the distance between any two points,  $(x_1, y_1)$  and  $(x_2, y_2)$ .

*Distance formula:*

$$d = \sqrt{(x_2 - x_1)^2 + (y_2 - y_1)^2}$$

The distance from (0,4) to (4,2) is the same distance as from (4,2) to (0,4), so it doesn't matter which point is designated as the first point  $(x_1, y_1)$  or the second point  $(x_2, y_2)$ . We'll prove this by calculating the distance both ways.

Suppose we let (0,4) be the first point and (4,2) be the second point; then  $x_1 = 0$ ,  $y_1 = 4$ , and  $x_2 = 4$ ,  $y_2 = 2$ . If we substitute these values into the distance formula and simplify, it will look like this:  $d = \sqrt{(x_2 - x_1)^2 + (y_2 - y_1)^2} = \sqrt{(4 - 0)^2 + (2 - 4)^2} = \sqrt{(4)^2 + (-2)^2} = \sqrt{16 + 4} = \sqrt{20} = \sqrt{4(5)} = 2\sqrt{5} \approx 4.47$ . The distance between the given points is approximately 4.47 units.

Now we'll reverse the points and call (4,2) the first point and (0,4) the second point. Then  $x_1 = 4$ ,  $y_1 = 2$ , and  $x_2 = 0$ ,  $y_2 = 4$ . If we substitute these values into the distance formula and simplify, it will look like this:  $d = \sqrt{(x_2 - x_1)^2 + (y_2 - y_1)^2} = \sqrt{(0 - 4)^2 + (4 - 2)^2} = \sqrt{(4)^2 + (2)^2} = \sqrt{16 + 4} = \sqrt{20} = 2\sqrt{5} \approx 4.47$ . No matter

which one we call the first point and which one we call the second point, the distance is still the same.

*Example 2:*

Find the distance between the points  $(-1,2)$  and  $(2,-1)$ .

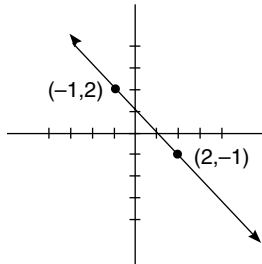

*Solution:*

We can choose either point to be the first point; the other point is the second point. We'll call  $(-1,2)$  the first point and  $(2,-1)$  the second point. Therefore,  $x_1 = -1$ ,  $y_1 = 2$  and  $x_2 = 2$ ,  $y_2 = -1$ .

$$d = \sqrt{(2 - -1)^2 + (-1 - 2)^2} \quad \text{Substitute the values into the distance formula.}$$

$$d = \sqrt{(2 + 1)^2 + (-3)^2} \quad \text{Minus a negative becomes plus a positive.}$$

$$d = \sqrt{(3)^2 + (-3)^2}$$

$$d = \sqrt{9 + 9}$$

$$d = \sqrt{18} = \sqrt{9(2)} = 3\sqrt{2} \approx 4.24$$

Suppose we wanted to find the coordinates of the halfway mark or midpoint of the line that connects the points in example 1. Would you know to use the midpoint formula? Given two points  $(x_1, y_1)$  and  $(x_2, y_2)$ , use the following formula to find the midpoint. As in the distance formula, it doesn't matter which point you call the first point and which point you call the second point; the midpoint will still be the same.

*Midpoint formula:*

$$\left( \frac{x_1 + x_2}{2}, \frac{y_1 + y_2}{2} \right)$$

*Example 3:*

Find the midpoint of the line segment that connects the points  $(0,4)$  and  $(4,2)$  in example 1.

*Solution:*

It doesn't matter which point we call the first point  $(x_1, y_1)$ . Let's call  $(0, 4)$  the first point, which makes  $(4, 2)$  the second point. Therefore,  $x_1 = 0$ ,  $y_1 = 4$  and  $x_2 = 4$ ,  $y_2 = 2$ . Substitute these values into the midpoint formula and simplify.

*Midpoint:*

$$\left( \frac{x_1 + x_2}{2}, \frac{y_1 + y_2}{2} \right) = \left( \frac{0 + 4}{2}, \frac{4 + 2}{2} \right) = \left( \frac{4}{2}, \frac{6}{2} \right) = (2, 3)$$

*Example 4:*

Find the midpoint of the line segment that connects the points  $(-1, 2)$  and  $(2, -1)$  in example 2.

*Solution:*

Let's choose  $(-1, 2)$  to be the first point; then  $(2, -1)$  has to be the second point. Therefore,  $x_1 = -1$ ,  $y_1 = 2$  and  $x_2 = 2$ ,  $y_2 = -1$ . Substitute these values into the midpoint formula and simplify.

*Midpoint:*

$$\left( \frac{x_1 + x_2}{2}, \frac{y_1 + y_2}{2} \right) = \left( \frac{-1 + 2}{2}, \frac{2 + -1}{2} \right) = \left( \frac{1}{2}, \frac{1}{2} \right)$$

## Line Segment

Here's our next definition: *A line segment is a section of a line between two points.*

Using that definition very carefully, see if you can identify all three line segments in the following line.

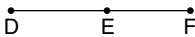

The three line segments in this line are  $\overline{DE}$ ,  $\overline{EF}$ , and  $\overline{DF}$ . A line drawn over two capital letters will stand for line segment. That's right,  $\overline{DF}$  is a line segment. Remember our definition: *A line segment is a section of a line between two points*—even if those points happen to be located at the two extremes of the line, with other points in between, and even if the section of the line is the entire line. The order in which we list the letters doesn't matter.  $\overline{DE}$  is considered to be the same line segment as  $\overline{ED}$ .

*Example 5:*

Identify all the possible line segments of the following line.

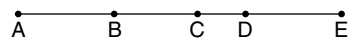



*Solution:*  
 $\overline{AB}, \overline{AC}, \overline{AD}, \overline{AE}, \overline{BC}, \overline{BD}, \overline{BE}, \overline{CD}, \overline{CE}, \overline{DE}$

## Ray

Finally we have a ray. *A ray has an end point at one end of a line and extends indefinitely in the other direction.* An arrow indicates the direction. The following is a ray.

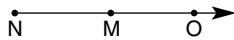

This ray can be written in the following ways. We'll put an arrow over a ray, with the arrow pointing in the same direction as the original ray.

$\overrightarrow{NM}, \overrightarrow{NO}$

*Example 6:*

List all the possible rays from the illustration below.

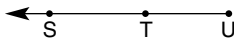

*Solution:*  
 $\overleftarrow{UT}, \overleftarrow{US}$

### SELF-TEST 1

- Find the distance of the straight line that connects these points:
  - (3,9) and (7,13)
  - (-5,3) and (3,7)
- Find the coordinates of the midpoint of the straight lines between these points:
  - (3,9) and (7,13)
  - (-5,3) and (3,7)

3. Identify all of the line segments of each of the following lines.

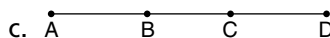
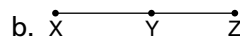

4. List all the possible rays of the following lines.

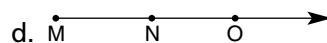
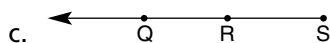
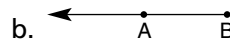
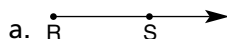

## ANSWERS

1.  $d = \sqrt{(x_2 - x_1)^2 + (y_2 - y_1)^2}$

a.  $x_1 = 3, y_1 = 9, \text{ and } x_2 = 7, y_2 = 13$

$$d = \sqrt{(7 - 3)^2 + (13 - 9)^2} = \sqrt{(4)^2 + (4)^2} = \sqrt{16 + 16} = \sqrt{32} = \sqrt{16(2)} = 4\sqrt{2} \approx 5.66$$

b.  $x_1 = -5, y_1 = 3, \text{ and } x_2 = 3, y_2 = 7$

$$d = \sqrt{(3 - (-5))^2 + (7 - 3)^2}$$

$$= \sqrt{(3 + 5)^2 + (7 - 3)^2} = \sqrt{(8)^2 + (4)^2} = \sqrt{64 + 16} = \sqrt{80} = \sqrt{16(5)} = 4\sqrt{5} \approx 8.94$$

2. *Midpoint:*

$$\left( \frac{x_1 + x_2}{2}, \frac{y_1 + y_2}{2} \right)$$

a.  $x_1 = 3, y_1 = 9, \text{ and } x_2 = 7, y_2 = 13$

*Midpoint:*

$$\left( \frac{3 + 7}{2}, \frac{9 + 13}{2} \right) = \left( \frac{10}{2}, \frac{22}{2} \right) = (5, 11)$$

b.  $x_1 = -5, y_1 = 3, \text{ and } x_2 = 3, y_2 = 7$

*Midpoint:*

$$\left( \frac{-5 + 3}{2}, \frac{3 + 7}{2} \right) = \left( \frac{-2}{2}, \frac{10}{2} \right) = (-1, 5)$$

3. a.  $\overline{AB}$   $\overline{AC}$   $\overline{BC}$

b.  $\overline{XY}$   $\overline{XZ}$   $\overline{YZ}$

c.  $\overline{AB}$   $\overline{AC}$   $\overline{AD}$   $\overline{BC}$   $\overline{BD}$   $\overline{CD}$

d.  $\overline{JK}$   $\overline{JL}$   $\overline{JM}$   $\overline{KL}$   $\overline{KM}$   $\overline{LM}$

4. a.  $\overrightarrow{RS}$

b.  $\overleftarrow{BA}$

c.  $\overleftarrow{SQ}$   $\overleftarrow{RQ}$

d.  $\overrightarrow{MN}$   $\overrightarrow{MO}$

## Angles

If two straight lines meet or cross each other at a point, an angle is formed. The point where the lines meet is called the *vertex* of the angle; the sides are called the *rays* of the angle. For example, in the following angle, the vertex is at the point B, and the rays are  $\overrightarrow{BA}$  and  $\overrightarrow{BC}$ .

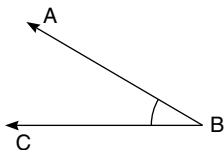

We use  $\angle$  as the symbol for an angle. The angle shown above can be called  $\angle ABC$  (where the middle letter names the vertex) or simply  $\angle B$ .

Angles are usually measured in degrees, but as we'll see in chapter 3, they can also be measured in radians. Perhaps the most familiar angle is the right angle. The

symbol for the right angle is a square drawn at the vertex. A right angle is formed when two perpendicular lines intersect, forming a  $90^\circ$  angle. The following is a drawing of a right angle.

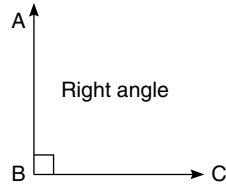

Most people can easily recognize right angles, but what about the following angle?

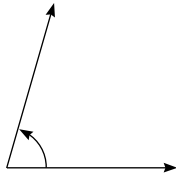

Would you be able to look at it and tell us it's  $67^\circ$ ? No one is that good, not even the authors. We can identify some angles just by looking at them. So the obvious question is: How do we find the measure of an angle? The answer is: Use a protractor.

Let's start by looking at a circle. A circle has  $360^\circ$ .

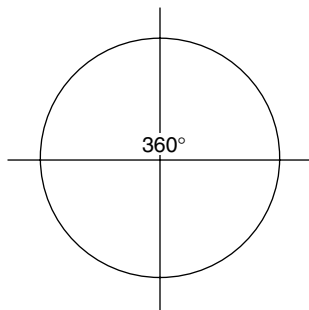

If we divide the circle into four equal parts formed by the intersection of two perpendicular lines, each part is  $90^\circ$ , a right angle.

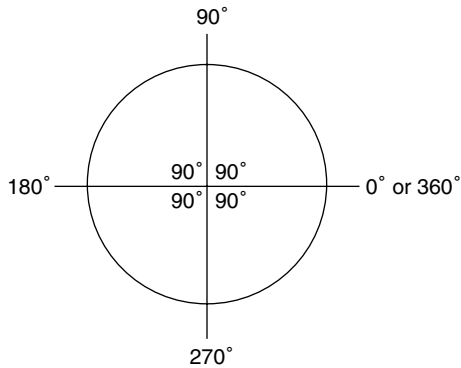

But how do we measure angles that aren't circles or right angles? The protractor measures the number of degrees of an angle. Any angle that moves counter-clockwise is positive; any angle that moves clockwise is negative. For the remainder of this section, we'll work only with positive angles. Go back three illustrations to the  $67^\circ$  angle. Looking at the angle, you can see it's between  $0^\circ$  and  $90^\circ$ . If you place your protractor over the angle with the vertex lined up with the line on your protractor, you'll find that the angle is  $67^\circ$ . *Angles between  $0^\circ$  and  $90^\circ$  are called acute angles.* The following figure shows an acute angle.

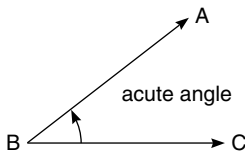

*Angles larger than  $90^\circ$  but smaller than  $180^\circ$  are called obtuse angles.* The following figure shows an obtuse angle.

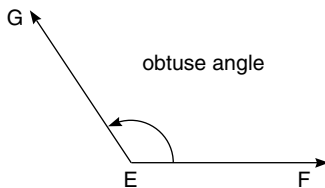

*Another type of angle is the straight angle, which measures  $180^\circ$ .* As you can see, a straight angle is a straight line.



We measure angles with the use of a protractor. As we mentioned, certain angles are so common that we know what they are just by looking at them. Angles of  $90^\circ$  and  $180^\circ$  are easily recognized. In addition, angles of  $30^\circ$ ,  $45^\circ$ ,  $60^\circ$ , and  $270^\circ$  are common.

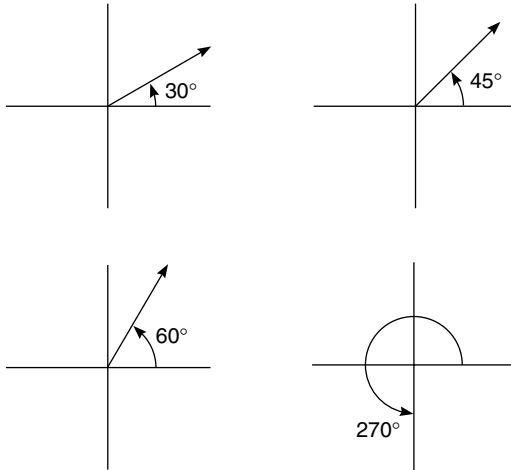

*Example 7:*

Use a protractor to measure the following angles and label them as acute, right, obtuse, or straight.

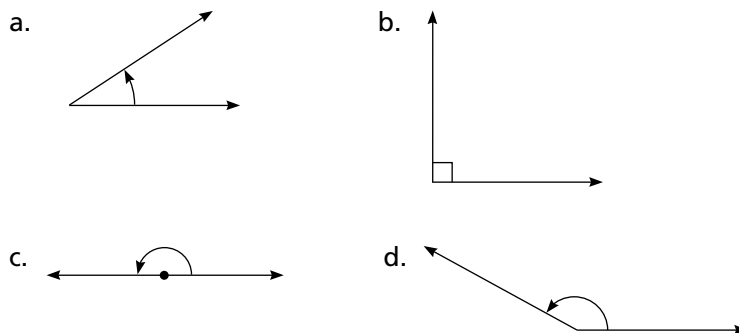

*Solution:*

- This angle is approximately  $32^\circ$ , which makes it an acute angle.
- This angle is  $90^\circ$ , which makes it a right angle.
- This angle is  $180^\circ$ , which makes it a straight angle.
- This angle is approximately  $150^\circ$ , which makes it an obtuse angle.

Angles  $f$  and  $g$ , shown in the following illustration, are *adjacent angles*. You'll notice that they have the same vertex. Therefore: *if two angles have the same vertex and are adjacent to each other, they are adjacent angles.*

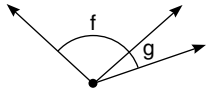

The sum of the two adjacent angles shown in the following illustration is  $90^\circ$ . *Any two angles whose sum is  $90^\circ$  are complementary angles.* So angles DEF and FEG are complementary. However, complementary angles do not have to be adjacent.

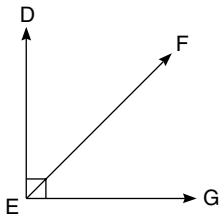

*Example 8:*

Find the value of  $x$  in the following illustration.

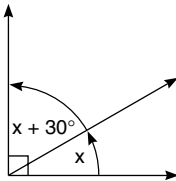

*Solution:*

These angles are complementary, so we know the sum of the angles is  $90^\circ$ .

$x + 30^\circ + x = 90^\circ$	Write this information in an equation form.
$2x + 30^\circ = 90^\circ$	Solve the equation by combining like terms.
$2x = 60^\circ$	Subtract $30^\circ$ from both sides of the equation.
$x = 30^\circ$	Divide both sides of the equation by 2.

The sum of the following two adjacent angles is  $180^\circ$ . *Any two angles whose sum is  $180^\circ$  are supplementary angles.* Angles  $r$  and  $s$  are supplementary.

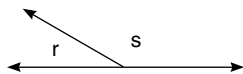

In the following figure, are angles  $w$  and  $v$  supplementary? They certainly are. But please note that like complementary angles, supplementary angles do not have to be adjacent. All that matters is the sum. Hold that thought for a few minutes and we'll show you some supplementary angles that are not adjacent.

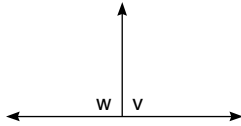

When two lines intersect each other, four angles are formed, and their sum is  $360^\circ$ .

$$a^\circ + b^\circ + c^\circ + d^\circ = 360^\circ$$

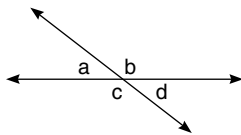

The sum of the adjacent angles is  $180^\circ$ .

$$a^\circ + b^\circ = 180^\circ$$

$$c^\circ + d^\circ = 180^\circ$$

$$a^\circ + c^\circ = 180^\circ$$

$$b^\circ + d^\circ = 180^\circ$$

*Angles that have the same degrees are called equivalent angles. The symbol for equivalent angles is  $\cong$ .*

*Angles diagonally opposite each other are called vertical angles, and they are equivalent.*

$$\angle a \cong \angle d$$

$$\angle b \cong \angle c$$

Two lines perpendicular to each other make up a special case. These lines form four right angles, as shown in the next figure.

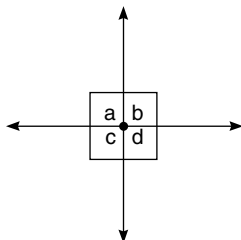

$$\angle a \cong \angle b \cong \angle c \cong \angle d \cong 90^\circ$$

$$\angle a + \angle b + \angle c + \angle d = 360^\circ$$

The following illustration is a transversal. *A transversal is a line that intersects two other lines.* The transversal intersects the two lines, forming eight angles numbered 1 through 8 in the figure.

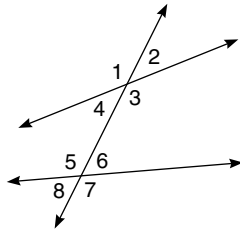

Here's another transversal. This time it crosses parallel lines.

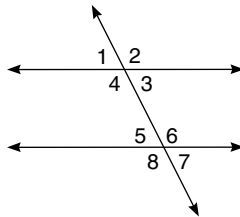

This transversal creates several different kinds of angles: corresponding, interior, and exterior. We will use the figure above to illustrate these three kinds of angles.

*Corresponding angles are two angles in corresponding positions relative to two lines.* The following pairs of angles are corresponding angles.

$$\angle 1 \text{ and } \angle 5 \quad \angle 2 \text{ and } \angle 6 \quad \angle 4 \text{ and } \angle 8 \quad \angle 3 \text{ and } \angle 7$$

Corresponding angles are congruent (have equal measure).

*Interior angles are angles between a pair of lines crossed by a transversal.* The interior angles are  $\angle 3$ ,  $\angle 4$ ,  $\angle 5$ , and  $\angle 6$ .

*Alternate interior angles are two nonadjacent interior angles on opposite sides of a transversal.* The following pairs are alternate interior angles.

$$\angle 4 \text{ and } \angle 6 \quad \angle 3 \text{ and } \angle 5$$

Alternate interior angles are congruent.

*Exterior angles are angles outside a pair of lines crossed by a transversal.* Exterior angles are  $\angle 1$ ,  $\angle 2$ ,  $\angle 7$ , and  $\angle 8$ .



The following are pairs of alternate exterior angles.

$\angle 1$  and  $\angle 7$        $\angle 2$  and  $\angle 8$

Alternate exterior angles are congruent.

The following pairs of angles are supplementary (they add up to  $180^\circ$ ).

$\angle 1$  and  $\angle 2$        $\angle 1$  and  $\angle 4$        $\angle 2$  and  $\angle 3$        $\angle 3$  and  $\angle 4$   
 $\angle 5$  and  $\angle 6$        $\angle 5$  and  $\angle 8$        $\angle 6$  and  $\angle 7$        $\angle 7$  and  $\angle 8$

If lines D and E are parallel, as shown in the following illustration, then  $\angle d = \angle g = \angle h = \angle k$  and  $\angle e = \angle f = \angle i = \angle j$ .

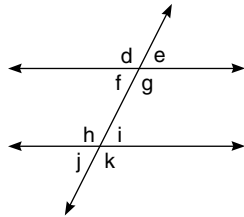

*Example 9:*

Find the values of the angles in the following illustration if  $\angle 1 = 135^\circ$ . Assume the lines, f and g, crossed by the transversal are parallel.

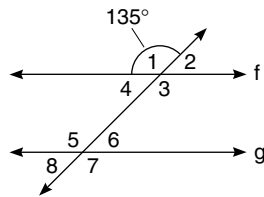

*Solution:*

- $\angle 1$  and  $\angle 3$  are vertical angles, which are congruent; therefore,  $\angle 3 = 135^\circ$ .
- $\angle 1$  and  $\angle 2$  are supplementary angles; therefore,  $\angle 2 = 180^\circ - 135^\circ = 45^\circ$ .
- $\angle 1$  and  $\angle 4$  are also supplementary; therefore,  $\angle 4 = 45^\circ$ .
- $\angle 4$  and  $\angle 6$  are alternate interior angles, which are congruent; therefore,  $\angle 6 = 45^\circ$ .
- $\angle 5$  and  $\angle 6$  are supplementary; therefore,  $\angle 5 = 135^\circ$ .
- $\angle 6$  and  $\angle 8$  are vertical angles; therefore,  $\angle 8 = 45^\circ$ .
- $\angle 5$  and  $\angle 7$  are vertical angles; therefore,  $\angle 7 = 35^\circ$ .
- $\angle 1 \cong \angle 3 \cong \angle 5 \cong \angle 7 = 135^\circ$ .
- $\angle 2 \cong \angle 4 \cong \angle 6 \cong \angle 8 = 45^\circ$ .

**SELF-TEST 2**

1. Identify the vertex of each of the following angles.

a.

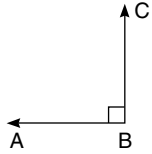

b.

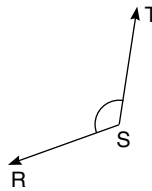

c.

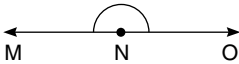

d.

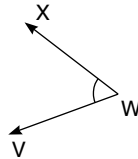

e.

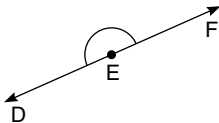

f.

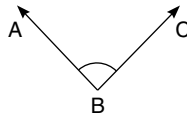

2. State whether each of the angles in the previous question is acute, obtuse, right, or straight.

3. Each of the following pairs of angles can be described as adjacent, complementary, or supplementary. Use one or two of these descriptions for each angle.

a.

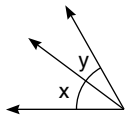

b.

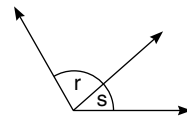

c.

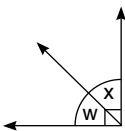

d.

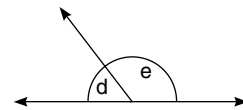

e.

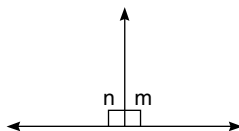

f.

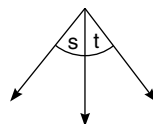

4. Use the following figure to answer these questions.
- What is the sum (in degrees) of angles  $a$ ,  $b$ ,  $c$ , and  $d$ ?
  - What is the sum of angles  $a$  and  $b$ ?
  - What is the sum of angles  $c$  and  $d$ ?
  - What is the sum of angles  $a$  and  $d$ ?
  - What is the sum of angles  $b$  and  $c$ ?

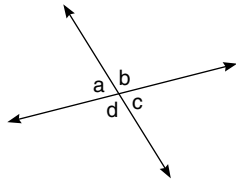

5. Find the degree of angles  $k$ ,  $l$ ,  $m$ ,  $n$ ,  $o$ ,  $p$ , and  $q$ . Assume the lines cut by the transversal are parallel.

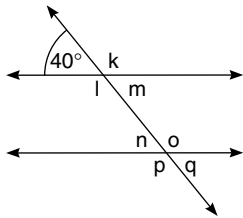

6. Find the degree of angles  $a$ ,  $c$ ,  $d$ ,  $e$ ,  $f$ ,  $g$ , and  $h$ . Assume the lines cut by the transversal are parallel.

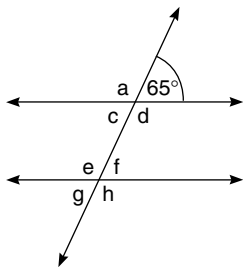

7. Find the value of  $x$  in the following illustration.

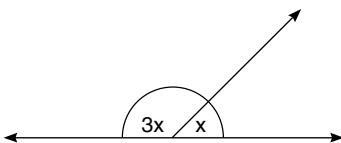

## ANSWERS

1. a. B      b. S      c. N      d. W      e. E      f. B
2. a. right      b. obtuse      c. straight  
d. acute      e. straight      f. acute
3. a. adjacent      b. adjacent  
c. adjacent, complementary      d. adjacent, supplementary  
e. adjacent, supplementary      f. adjacent
4. a.  $360^\circ$       b.  $180^\circ$       c.  $180^\circ$       d.  $180^\circ$
5.  $k = 140^\circ$     $l = 140^\circ$     $m = 40^\circ$     $n = 40^\circ$     $o = 140^\circ$     $p = 140^\circ$     $q = 40^\circ$
6.  $a = 115^\circ$     $c = 65^\circ$     $d = 115^\circ$     $e = 115^\circ$     $f = 65^\circ$     $g = 65^\circ$     $h = 115^\circ$
7.  $3x + x = 180^\circ$   
 $4x = 180^\circ$   
 $x = 45^\circ$

## Polygons

*A polygon is a closed planar figure that is formed by three or more line segments that all meet at their end points; there are no end points that are not met by another end point.*

Two of the most common polygons are triangles (to which we've devoted all of the next chapter) and quadrilaterals.

Quadrilaterals are four-sided figures. Shown below are the four most common quadrilaterals.

*A square is a quadrilateral that consists of all right angles and equal sides.*

*A rectangle is a quadrilateral that consists of four right angles where opposite sides are parallel and equal in length.*

*A trapezoid is a quadrilateral with exactly one pair of parallel sides.*

*A parallelogram is a quadrilateral with both pairs of opposite sides parallel.*

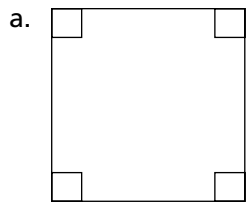

square

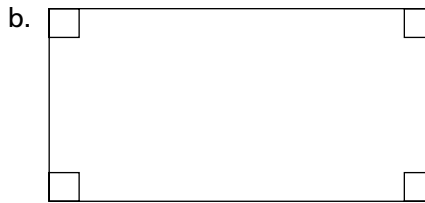

rectangle

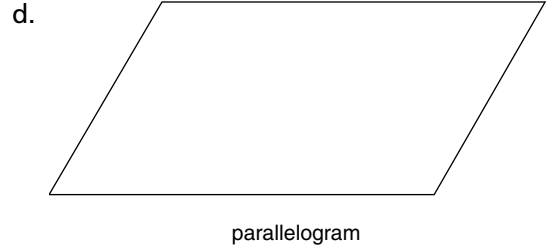
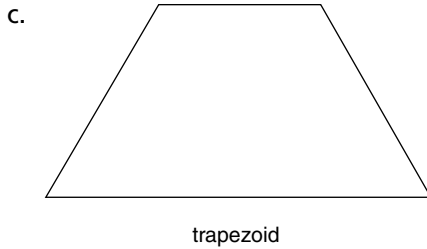

All quadrilaterals contain  $360^\circ$ . The square and the rectangle each contain four angles of  $90^\circ$ .

The trapezoid and the parallelogram each contain two angles of more than  $90^\circ$ . A few pages back we said that supplementary angles could be adjacent or nonadjacent. Trapezoids contain two sets of nonadjacent supplementary angles. So, too, do parallelograms. The following illustrations show an example of each.

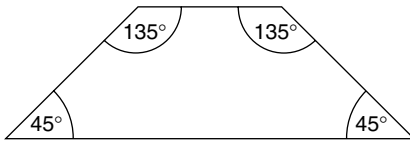

How many degrees are angles A, B, and C in each of the following polygons?

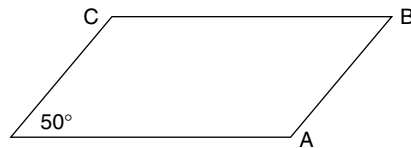
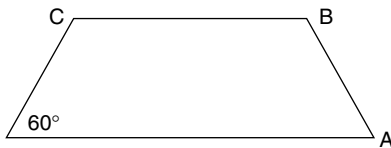

In the figure, the trapezoid contains angles A ( $60^\circ$ ), B ( $120^\circ$ ), and C ( $120^\circ$ ). The parallelogram contains angles A ( $130^\circ$ ), B ( $50^\circ$ ), and C ( $130^\circ$ ).

So far we've covered just quadrilaterals. Can you guess what a five-sided polygon is called? It's called a pentagon. Of course, the most famous pentagon is the headquarters of the U.S. Department of Defense, a five-sided building just outside Washington, D.C. Try to guess what a six-sided polygon is called. It's a hexagon. We'll tell you the next four—a seven-sided polygon is a heptagon; one with eight sides is an octagon; one with nine sides is a nonagon; and one with ten sides is a decagon.

We've already seen that the sum of the four angles of a quadrilateral is  $360^\circ$ . Now we'll give you the formula that provides the sum of all the angle measurements in any polygon:

The sum of all angles in an  $n$ -gon =  $(n - 2)180^\circ$ , where  $n$  is the number of angles (or sides) in the polygon.